

## Electronic Conduction In Insulating Crystals Under Very High Field Strength

A. VON HIPPEL

*Electrical Engineering Department, Massachusetts Institute of Technology, Cambridge, Massachusetts*

(Received September 19, 1938)

After a short discussion of electronic conduction in insulators with the main emphasis placed on the electrostatic coupling between electron and lattice, new experimental results are given: Current-voltage characteristics and photoelectric response have been measured in single crystals up to the breakdown point. Ten million volts per centimeter have been reached in mica, and phenomena have been observed acoustically, making a crystalline type of light-counter feasible. The dark-currents and photocurrents observed give information about the mechanism of electric conduction under very high field strength.

### 1. THE BEHAVIOR OF ELECTRONS AND HOLES IN INSULATING CRYSTALS

SINCE the development of Bloch's theory of electronic conduction in metals and its very successful application, many authors have believed that the only difference between metals and insulators lies in the zone structure of the electronic levels. In a good conductor the lowest band is half-filled or the allowed bands overlap; in a good insulator the lowest band is completely filled and the next higher allowed zone is empty and distinctly separated.<sup>1</sup> According to this conception, to convert the insulator into a conductor, it is only necessary to transfer electrons from the lower into the upper band. The electrons transferred and the positive holes left in the lower zone will be free to move through the lattice and to establish metallic conduction.

For a number of years the author, studying the behavior of insulating crystals under very high field strengths, has stressed the point that this zone picture for insulators does not contain the whole story. It has to be supplemented by a consideration of the decisive influence of the electric forces coupling the movement of the electrons to the heavy building stones of the lattice. In ionic crystals this coupling is so strong that the moving electrons can be treated rather as charged particles than as electron waves. As shown in previous papers the most important consequences of this situation are the following:

The lower filled band in such crystals as the alkali-halides consists of electrons *locally* bound to the lattice points. Excitation to the next higher states does not bring the electrons into a

<sup>1</sup> Cf. for instance, F. Seitz and R. P. Johnson, *J. App. Phys.* **8**, 84, 186, 246 (1937).

conduction band but into *locally bound* excited states, which can be seen in two groups of double bands in the absorption spectrum of the crystals.<sup>2</sup> During the lifetime of such excited states the lattice rearranges itself, and dissipates a part of the excitation energy into lattice vibrations.<sup>2, 3</sup> This distortion of the crystal has not only the consequence of shifting the frequency of the light emitted compared with that of the light absorbed, but it can even prevent re-emission, because the electron in the reverse process has to pay for the lattice distortion.<sup>4</sup> Heat vibration and light absorption can transfer an electron from an excited state into a conducting state, but its behavior is also then very different from that of a metal electron: The electron acts like a space charge, distorting the lattice as it moves along; that is it emits and also absorbs phonons in its migration.<sup>5</sup> These conducting electrons travel in preferential lattice directions;<sup>6</sup> if their velocity becomes too low, they are trapped by the lattice disturbance created by their presence.<sup>7, 8</sup> This

<sup>2</sup> A. von Hippel, *Zeits. f. Physik* **93**, 86 (1934).

<sup>3</sup> A. von Hippel, *Zeits. f. Physik* **101**, 680 (1936).

<sup>4</sup> The two-dimensional potential diagram Fig. 1 may elucidate this situation in a clearer way than the picture given originally by the author: An electron has been raised by light absorption from *A* to *B*. In the condensed system the oscillation energy becomes rapidly dissipated and lowers the excited state to *C*. Now a temperature vibration must lift the state to *D*, before it can fall back to the original state *A* by again dissipating the oscillation energy. More likely in the case illustrated is the direct transfer *B-D-A* dissipating the total light quantum absorbed in one act into heat. This accounts apparently for the experimental observation, that at low temperatures light can be absorbed in ionic crystals without any visual effect. The author has given a detailed discussion elsewhere (reference 3).

<sup>5</sup> A. von Hippel, *Zeits. f. Physik* **75**, 145 (1932).

<sup>6</sup> A. von Hippel, *Zeits. f. Physik* **68**, 309 (1931).

<sup>7</sup> A. von Hippel, *Ergebn. d. Exakt. Naturwiss.* **14**, 113 (1935).

<sup>8</sup> L. Landau had already proposed a quantum mechanical trapping mechanism for electrons (*Physik. Zeits.*

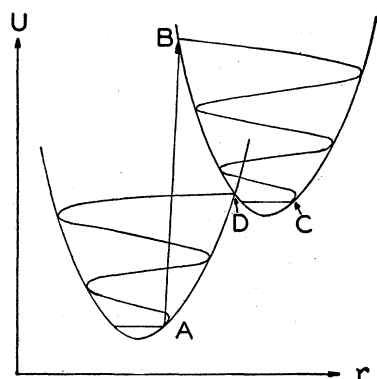

FIG. 1.

trapping makes phosphorescence possible.<sup>3</sup> Under the influence of very high field strength, on the other hand, the electrons can reach velocities which make the excitation of lattice vibrations unlikely; acceleration, impact ionization, and electric breakdown result.<sup>5</sup>

According to this conception the assumption that the holes left in the lower filled levels of the insulator can be treated like free conducting positrons also does not seem completely justified. These holes correspond in the alkali-halides to neutral halogen atoms; they can be trapped like the surplus electrons, but the lattice distortion created will be different. Therefore light absorption of different position and probability will bring the electron and the hole back from the fixed state into the mobile state.<sup>3</sup> Moreover, the migration process differs appreciably: the surplus electron may travel relatively smoothly over larger distances; the hole has to move over much rougher potential hills corresponding to the classical picture of an electron exchange from neighbor to neighbor (Fig. 2).

The viewpoints summarized above have been gained by the author in discussing his own experimental results and those of R. W. Pohl and

Sowjetunion 3, 664 (1933)), as the author has now found out, but our ideas are different. According to Landau, slow electrons cannot be trapped because their position is badly defined on account of their long wave-length. They have to be speeded up by an activation energy before they can be caught locally. The author on the other hand, feels that such an activation energy is not needed; on the contrary, the slow electrons are most liable to become trapped on account of the coupling mechanism outlined above. (In a private communication Dr. Teller stated more accurately: the potential energy  $u = -e^2/r$  of the electron decays as  $1/r$  but its kinetic energy  $(h/\lambda)^2 \cdot 1/2m$  decays as  $1/r^2$  and is therefore smaller than  $u$  for slow electrons).

his co-workers. Some recent theoretical papers have reached confirming conclusions:

Frenkel<sup>9</sup> postulated independently and at about the same time as the author the existence of trapped excited states called excitons and of trapped electrons and holes. Wannier,<sup>10</sup> Seitz,<sup>11</sup> and Mott<sup>12</sup> find excitation states below the ionization states in the alkali-halide crystals. Seitz<sup>11</sup> calculated the phosphorescence of the alkali-halide-thallium crystals by using the mechanism of lattice distortion. Seeger and Teller,<sup>13</sup> computing the interaction between conducting electrons and the ionic lattice, find the high friction for the electrons and the right order of magnitude for the breakdown strength.<sup>14</sup>

In the present paper the author presents some new experimental results about the electric conduction of insulating crystals in the range of very high field strength. It seems that the phenomena observed fit into the picture<sup>15</sup> given above.

## 2. EXPERIMENTAL ARRANGEMENT

The goal of the experiments was to measure the current-voltage characteristic in single crystals, especially in the alkali-halides, up to the breakdown point. Some preliminary curves have already been published by the author<sup>7</sup> rejecting a statement of Inge and Walther<sup>16</sup> that the electronic currents before breakdown could reach

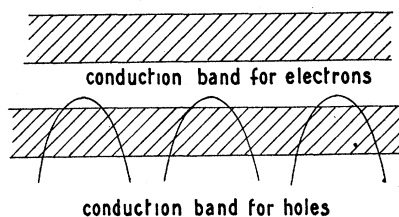

FIG. 2. Difference in the conduction bands of electrons and of holes.

<sup>9</sup> J. Frenkel, *Physik. Zeits. Sowjetunion* **9**, 158 (1936).

<sup>10</sup> G. H. Wannier, *Phys. Rev.* **52**, 191 (1937).

<sup>11</sup> F. Seitz, *J. Chem. Phys.* **6**, 150 (1938).

<sup>12</sup> N. F. Mott, *Trans. Faraday Soc.* **34**, 500 (1938).

<sup>13</sup> R. J. Seeger and E. Teller, *Program Washington Meeting, 1938*, No. 47; *Phys. Rev.* **54**, 515 (1938).

<sup>14</sup> The interesting theory of H. Fröhlich, *Proc. Royal Soc. London* **160**, 230 (1937), realizes the important electrostatic coupling mechanism between electrons and lattice, but does not take the dielectric constant into account.

<sup>15</sup> Cf. also A. von Hippel, *J. App. Phys.* **8**, 815 (1937).

<sup>16</sup> L. Inge and A. Walther, *Archiv f. Elektrot.* **28**, 729 (1934).

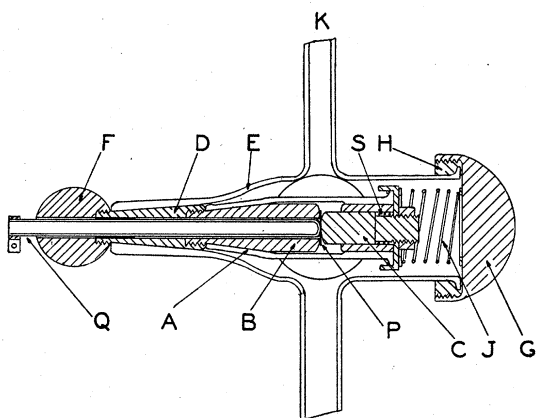

FIG. 3. Cross section of the crystal holder.

the magnitude of many amperes and would destroy the insulator by heat. The currents actually found directly before breakdown were of the order of  $10^{-9}$  to  $10^{-8}$  ampere, but they showed besides a tendency to decrease in time, and other peculiarities, which made the reconstruction of the apparatus and additional photoelectric measurements advisable.

A cross section of the crystal holder is given in Fig. 3. An interior glass tube *A* contains the two electrodes *B* and *C* holding the crystal plate *P* between themselves by the soft spring action of the spiral *S*. One of the highly polished steel electrodes (*B*) has at its center a longitudinal hole fitting a quartz tube *Q* polished on the end to the curvature of the metal surface. The quartz is covered by a semi-transparent Pt layer and is insulated over its length from the electrode by a very thin layer of glyphtal lacquer. A conical piece *D* fixes *B* in *A* and fits into a second glass tube *E*; a sphere *F* catches *D* from the outside. The other end of *E* is closed by a hemispherical brass piece *G* which screws over the ring *H* and presses the cone *D* into place by a spring *J*. Longitudinal illumination of the crystal under high voltage is possible through the quartz tube, transverse illumination through two opposite quartz windows on *E* lined up with holes in the inside tube *A*. The vessel *E* can be evacuated through the glass tube *K* and can then be filled with an insulating liquid (oil or pyranol).

The electrode *G* was connected to the high voltage side of a power pack; the rectified voltage of the pack (range 5 kv and 20 kv) was smoothed by large condensers. The electrode *F* was con-

nected to ground; hence the electrode *B* was the shield connected to the outside of a concentric cable, which protected the measuring electrode, the metal layer of the quartz tube *Q*, against disturbances. From the contact *L* the shielded lead connected to the grid of a *P* 54 tube used in a Barth circuit<sup>17</sup> arrangement. The total insulation was sufficient for measuring safely between  $10^{-12}$  and  $10^{-5}$  ampere by switching to different grid resistors. The voltage across the sample was measured with high resistances (order  $10^8$  ohm) and a Rubicon galvanometer. Resistances and a glow discharge tube protected the circuit against excess currents after breakdown.

For the photoelectric measurements a double monochromator was constructed with motor-drive and wave-length control. A General Electric tungsten band lamp and a mercury lamp of the Hippel type<sup>18</sup> served as light-sources. The intensity of the monochromatic radiation was measured by a vacuum thermopile of the Cartwright type and a Cs-vacuum-photo-cell.

### 3. RESULTS

Figures 4 to 7 give a characteristic picture of the phenomena observed when a KCl crystal plate of  $120\mu$  thickness is used.

In the dark the current begins to rise rapidly

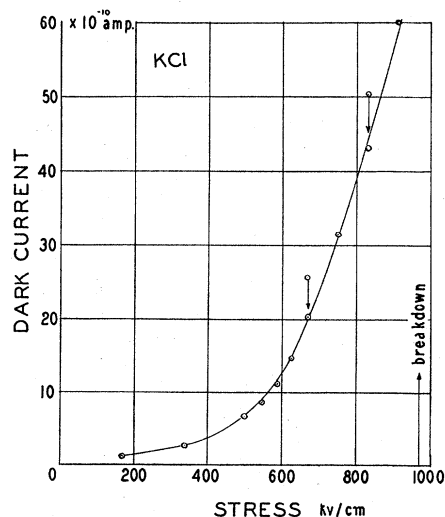

FIG. 4. Current-field-strength characteristic of the dark-current in KCl up to the breakdown point.

<sup>17</sup> Cf. D. B. Penick, Rev. Sci. Inst. 6, 115 (1935).

<sup>18</sup> W. Harries and A. von Hippel, Physik. Zeits. 33, 81 (1932).

under the influence of higher field strengths, but even at the breakdown point it is not higher than about  $8 \cdot 10^{-9}$  ampere. The breakdown appears suddenly as an abrupt instability, but the approach of the breakdown point often announces itself quite clearly through the time dependence of the dark-current. Normally after shifting to a higher voltage the current decays in time, as indicated on two points of the curve (Fig. 4) by arrows. Shortly before breakdown the current value often fluctuates unsteadily and may even increase with time.

Illuminated with visible or ultraviolet light down to 2500A, the clear untreated crystal does not show any photoelectric reaction. But if the crystal has been colored with *F* centers by migration of electrons, the situation changes completely. Fig. 5 gives the transmission curve of the colored crystal plate measured by the recording color-analyzer of Professor Hardy. Besides the well-known *F* band, an absorption in the violet appears which belongs to a surface coloration by electrons. Such surface bands can be observed in many crystals and glasses, and they can be understood by viewpoints given elsewhere.<sup>15</sup>

Figure 6 shows the photoelectric response of the colored crystal for constant light intensity and constant field strength; the electric curve matches the absorption curve almost perfectly. In addition, Fig. 7 gives the photoelectric current-voltage characteristic for constant illumination with the green mercury line. The light-current becomes about saturated where the dark-current

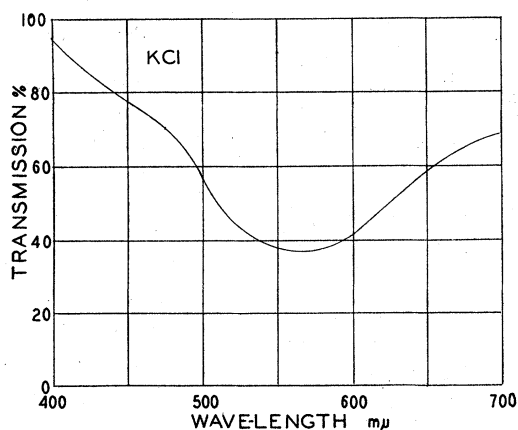

Fig. 5. The transmission curve of the KCl crystal.

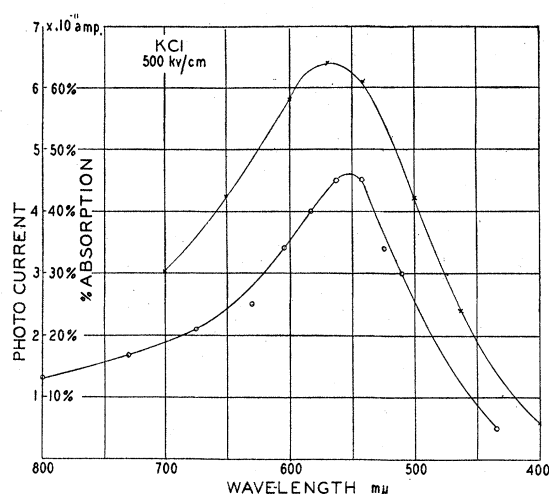

Fig. 6. The photoelectric response  $\circ$  of the KCl crystal compared with the curve of light absorption  $\times$ . (The percent values of the absorption correspond to a larger crystal from which the sample was split, and have therefore only relative meaning.)

rises steeply.<sup>19</sup> The light-current is proportional to the light intensity, so far as has been measured.

The photoelectric response can be used to explain why the dark-current depends upon time: In going backwards with the voltage, a point is reached where the photocurrent becomes zero; for lower voltages it becomes negative. Hence a space charge has been built up, measured in magnitude by the voltage of zero response. In this crystal the polarization voltage amounted to 700 volts corresponding to 58 kv/cm, if the field strength is assumed to be equally distributed across the crystal.

As a second example, the curves of a KBr crystal are given, which had not been quenched after coloring. Accordingly, its transmission curve (Fig. 8) shows a very broad absorption (formation of colloidal particles), but the photoelectric response indicates clearly the position of the *F* band (Fig. 9). The quantum yield of the *F* centers seems to be higher than that of colloidal particles, as one may expect. The photoelectric sensitivity of the KBr crystal at 600  $m\mu$  was about three times as high as that of the Cs-photo-cell<sup>20</sup> for the same wave-length, if the filter action of the platinized quartz tube was

<sup>19</sup> The last points of the photocurrent curve are not very accurate on account of the large and fluctuating dark-current; it may be that the photocurrent even decreases for the highest field strength.

<sup>20</sup> Pressler photo-cell, Cs-vacuum type.

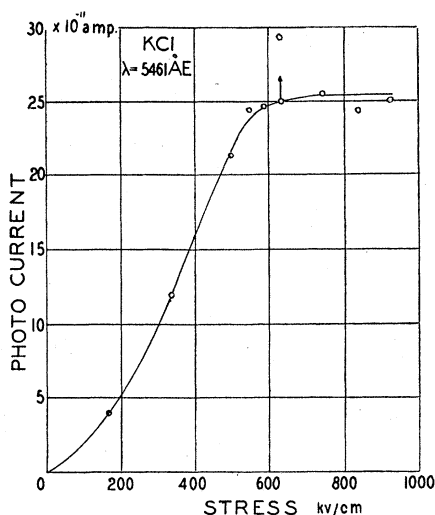

FIG. 7. Photoelectric current as function of field strength in KCl for the green mercury line.

taken into account. The Pt layer proved to be a neutral filter for the spectral range used. An interesting time effect could be observed on the KBr photocurrent: Red illumination gave a response decaying in time; toward shorter wavelength this after-effect became less and less pronounced, disappeared at about  $540 \text{ m}\mu$ , and changed sign towards an increase with time in the bluer spectral range.<sup>21</sup>

Coloring of a KBr crystal with Cu atoms by the author's electric method<sup>22, 23</sup> did not produce any marked photosensitivity. This is to be expected when one considers the great tendency of copper ions to recapture electrons.<sup>15</sup>

#### 4. CONTROL MEASUREMENTS WITH ANOTHER APPARATUS

On account of the fact that for the first time current-voltage characteristics have been obtained in the range of highest field strength, it seemed desirable to check the results in a quite

<sup>21</sup> This phenomenon apparently corresponds to the Herschel effect: The light absorption of the colloidal particles creates smaller centers absorbing farther towards the blue, hence the absorption in the red decreases in time. The bands of the different centers partly overlap, for light of shorter wave-length, therefore, the increase of *F* centers compensates and overcompensates the decrease in the number of bigger colloidal particles.

<sup>22</sup> A. von Hippel, *Zeits. f. Physik* **98**, 580 (1936).

<sup>23</sup> The author has been kindly advised by Professor Pohl that already in 1933 Miss Marietta Blau produced and measured for spectroscopic reasons the Cu coloration in NaCl and KCl (*Nachr. Göttinger Gesellschaft d. Wissenschaften II*, No. 51, 1933).

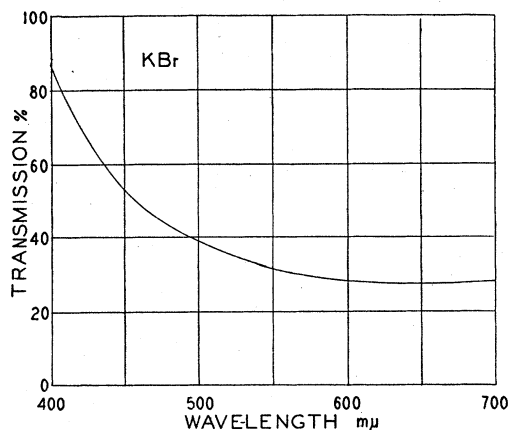

FIG. 8. Transmission curve of a KBr crystal, slowly cooled.

different experimental arrangement. Therefore the crystal-holder shown in Fig. 10 had been constructed. The crystal-plate is again placed between two metal electrodes *B* and *C*; the insulated metal core of *B* acts as measuring electrode. But the main change is that this holder can be screwed into a steel pipe which can be evacuated or can be connected to a nitrogen tank. Hence the high voltage measurements can be made under a pressure of 100 atmospheres of  $\text{N}_2$ , which together with a dielectric guard ring<sup>7</sup> forms a very effective shield against edge effects.

The dark-currents measured with this arrangement check the results obtained above perfectly. Fig. 11 presents the currents through three different alkali-halides, NaCl, KBr and RbI, on

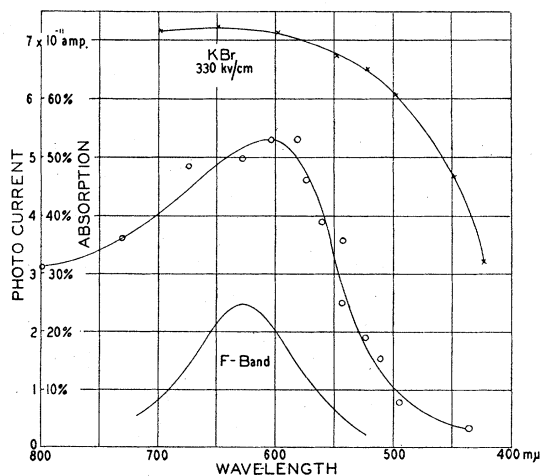

FIG. 9. Photoelectric response  $\circ$  and relative absorption  $\times$  of the KBr crystal compared with position of the *F* band.

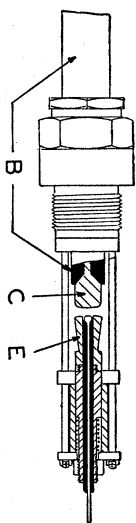

FIG. 10. Cross section of the second crystal holder. (The black insulation is amber.)

a reduced voltage scale. The ratio of field strength to breakdown field strength has been plotted; this shift makes the curves practically coincide.

A much larger current range is covered by measurements on a clear mica sheet of about  $6.5\mu$  thickness, shown in Fig. 12. Here about  $3 \cdot 10^{-8}$  ampere have been reached with the amazing field strength of about ten million volts per centimeter.<sup>24</sup> Even in this case the character of the phenomenon is not altered; the breakdown appears as an abrupt discontinuity; below this point the current can be drawn for considerable time without apparent harm.

A simple exponential relation between current and voltage as proposed by Poole<sup>25</sup> does not hold in this high field strength range.

### 5. ACOUSTICAL OBSERVATIONS

If the measuring electrode is connected not to an electrometer tube but to a high gain amplifier with loudspeaker, some interesting observations can be made: A rattling noise resembling that of a fast-counting Geiger counter can be heard, increasing very much in intensity with voltage, and dying out in time to fewer and fewer impulses, if the dark-current decreases with time. A similar statistical counting effect is produced by illumi-

<sup>24</sup> The thickness of the mica has been measured with an optical micrometer of Zeiss; the value may have an error of 10 percent.

<sup>25</sup> H. Poole, *Phil. Mag.* 42, 488 (1921).

nation, constant apparently in time, very much increasing in intensity with voltage. If the crystal was illuminated with a flashlight through the quartz window of the holder (Fig. 4) a noise resembling machine-gun fire could be produced at the highest field strength.

The possibility exists that here single electronic avalanches have been heard, and that a crystal-photon-counter can be constructed.

### 6. DISCUSSION

It seems unlikely that the dark-current corresponds to electrolytic conduction; its steep rise with voltage, its rapid fluctuations, and its noisiness point towards an electronic phenomenon. Assuming this, the observations form a consistent picture:

Electrons pulled from the cathode into the crystal by the high field strength applied, are transported over the rows of the cations (Fig. 13) towards the anode. A part of them comes through, others after progressing an average displacement distance  $w$  in field direction become trapped. Correspondingly a space charge forms decreasing the field strength at the cathode, the current

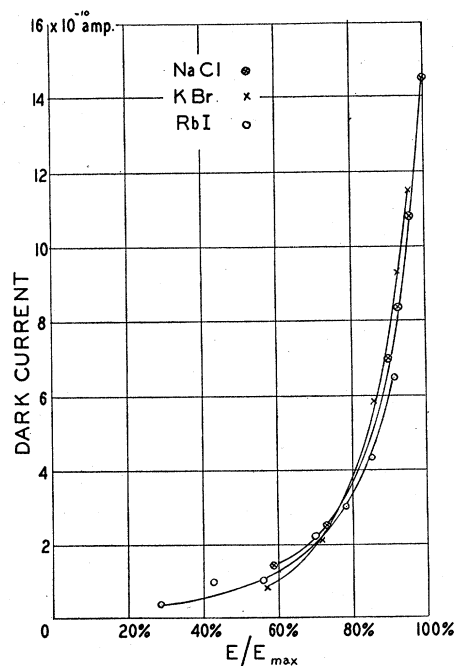

FIG. 11. The dark-current in NaCl, KBr and RbI compared on a reduced-voltage scale.

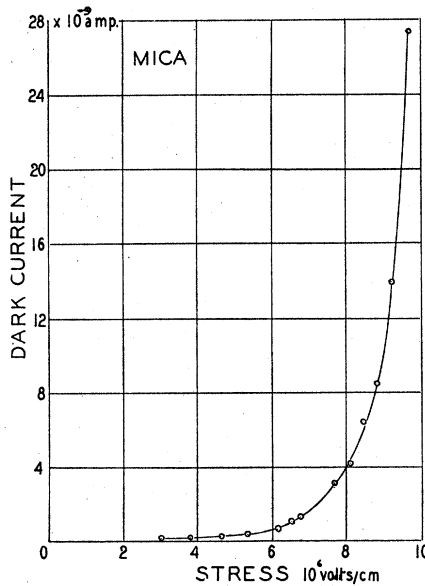

FIG. 12. Dark-current in mica.

decays in time. The negative space charge increases the field strength towards the anode and the displacement distance  $w$  increases proportional to the field strength,<sup>26</sup> hence electrons liberated from their trapped position by a heat vibration of the lattice will reach the anode. Besides the field distribution favors a second kind of electron migration (Fig. 13), a pulling *in* of electrons from halogen ions into the anode and transfer of the neutral halogen atoms by electron exchange through the rows of the anions to the cathode or to the space charge zone, where they recapture their electron (hole-migration).

The result is a dark-current steeply increasing with field strength on account of the field emission of the electrodes and decaying in time asymptotically towards an equilibrium value on account of the space charge formed (Figs. 4, 11 and 12). The number of trapped electrons is normally too small to be detected photoelectrically against the background of the dark-current. But a primary discolored crystal with its large number of  $F$  centers demonstrates the capture of electrons directly in its saturation curve (Fig. 7). The photocurrent as a function of voltage should approach a saturation value of  $\frac{1}{2}$  electron per quantum absorbed, if  $w$  becomes

<sup>26</sup> K. Hecht, *Zeits. f. Physik* **77**, 240 (1932).

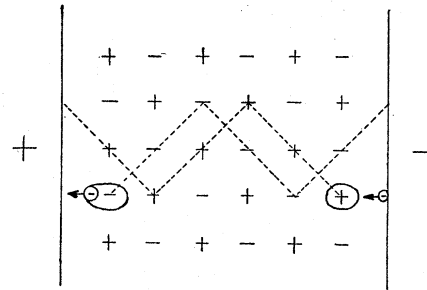

FIG. 13. Schematic diagram of the two types of electronic conduction.

comparable to the electrode distance  $d$ .<sup>27</sup> In Fig. 7 this seems the case at 600 kv/cm for  $d=120\mu$ , a value not inconsistent with those measured by Pohl and his co-workers at lower field strength.<sup>28</sup> An accurate comparison cannot be made, because the concentration of color centers in our case is not known.<sup>4</sup>

According to this conception the steep rise of the current-voltage characteristic is mainly due to field emission, not to ionization processes. The probability of speeding up surplus electrons to ionizing velocities does not become appreciable before the breakdown voltage, and then breakdown starts immediately, because the large number of impacts across the crystal creates very high avalanches and a field distortion accelerates the process.<sup>15</sup> But at local inhomogeneities of the lattice short avalanches may be produced earlier and thus account for a part of the noise observed. Some noise may originate from surface charges and some from a transport of charges by jerks.

Before discussing further details, the experimental material has to be improved. A greater variety of crystals treated in different ways should be measured, the current-voltage-time characteristics should be recorded, and the temperature dependence of the phenomena should be studied. Besides a clear picture has to be gained about the influence of the lattice structure on the electronic conduction linking our field to that of the semi-conductors. Adequate experimental methods are under development.

Some of the KCl and KBr crystals used were furnished by Professor D. C. Stockbarger, to whom the author wishes to express his thanks.

<sup>27</sup> R. Hilsch and R. W. Pohl, *Zeits. f. Physik* **108**, 60 (1938).

<sup>28</sup> R. W. Pohl, *Physik. Zeits.* **39**, 45 (1938).